

Labeler for Pint, Quart and One Gallon Cans

The new Langguth E 40-P Hot - Melt Labeler is the ideal machine for applying full-wrap paper and plastic labels to pint, quart and one-gallon paint cans, where hot-melt is the preferred adhesive.

The E 40-P is equipped with a patented, non contact glue system that utilizes a single Nordson unit to supply hot melt to both pick-up and lap glue applicators without any direct contact with the containers. There are no glue rollers, no open glue pots and no glue re-circulation in this unique system.

The Langguth E 40-P can be changed over from pint to quarts to one-gallon cans (with or without lugs) without tools. Since each E 40-P is equipped with a fully adjustable label magazine and there are no change parts in the glue system, the complete changeover takes only a few minutes.



Unlike conventional labelers, the Langguth E 40-P handles the cans in an upright position, eliminating the need for can twists before and after the labeler. For this reason the cans may be handled empty or full, without fear of spillage. In addition to the benefits noted above, the Langguth E 40-P has another important benefit savings. The E 40-P uses 30% less glue than other hot-melt systems.

While this factor alone can often justify the switch to the Langguth labeling technology, we encourage you to consider the benefits of decreased down time, reduced maintenance, minimal clean up and improved product image that are all part of the Langguth E 40-P package.

The Langguth E 40-P offers the most advanced labeling technology available for the paint industry.

E 40-P

Labeling machine

Unlike other labeling systems, the Langguth E 40-P has a single, hot-melt glue applicator that never touches the cans. Since the glue system is closed and the hot-melt is not exposed to the air, there are no fumes, no glue build-up and therefore no mess. Clean-up of the system at the end of the shift consists of purging air through the nozzles for appx. 20 seconds. The fully adjustable label magazine can be filled while the machine is running production, without the fear of losing the registration.

The quality of the label application is excellent every time. Excessive glue on the labels, poorly registered labels, wasted labels and containers needing rework are eliminated. Capable of operating at speeds up to 120 CPM on pints and quarts and 60 CPM on full, 80 CPM on empty, one-gallon cans with lugs, the Langguth E 40-P is the finest labelling machine available in the world today, where full-wrap labeling is

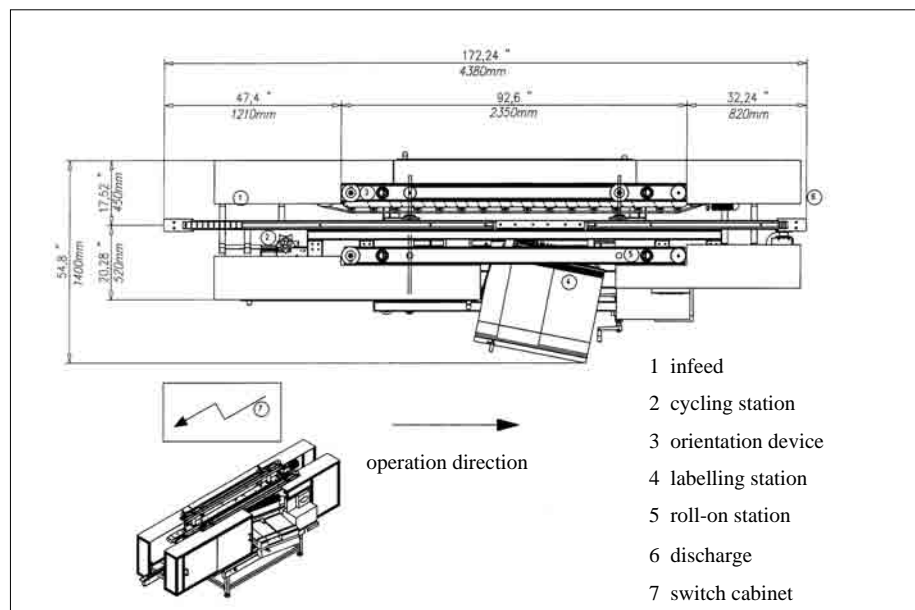

Technical Data

Capacity	Pint, Quart 120 cpm / one-Gallon 60 cpm filled	80 cpm empty
Gluing	Hot-Melt: spiral glue spots for pick up	Vertical glue strip on overlap
Construction	In-line-labeler; right hand and left hand available	
Label types	Wrap around labels	Incl. orientation for lugs
Containers	Cylindrical	
Container sizes	2"1/2 to 11" diameter	3" to 11" height
Label sizes	Label length:: 8" to 22" Label height: 2" to 8" fully adjustable	
Electrical specification	230 V - 480 V, 60 Hz, 3 phase	Control panel stand alone type
Connected load	Max. 8 kW	
Air consumption	2,5 cfm at 80 psi	
Dimensions	165-3/4" long, 62-3/4" wide	Infeed and discharge extentions can be provided

**Priority One
Packaging Machinery Ltd.**

815 Bridge Street
Waterloo, ON N2V 2M7
Phone: 519-746-6950
Fax: 519-746-3578
<http://www.priorityonepackaging.com>

LANGGUTH GmbH

Im Südfeld 17 · D-48308 Senden-Bösensell
Telefon +49 (0) 2536-806-0
Telefax +49 (0) 2536-806-66
E-mail: info@langguth.com
Internet: <http://www.langguth.com>