

NEW

Pressure Sensitive Pail Labeller E 36

Features:

- Will apply pressure sensitive labels to plastic and metal pails of all sizes and shapes (round, oval, square and rectangular)
- Will apply paper and plastic labels of any shape to tapered and straight-walled containers
- Will apply clear film labels for the “No Label” look
- Compact design for easy integration into existing lines
- Optional devices for pail and handle orientation are available



Front view

E 36

Method of operation

Pails are metered into the E 36 one at a time. Pressure sensitive labels are fed from a roll into position on a vacuum plate. As the containers pass the plate, the labels are picked up and firmly "squeeged" into position on the passing pails.



Label transfer at vacuum plate

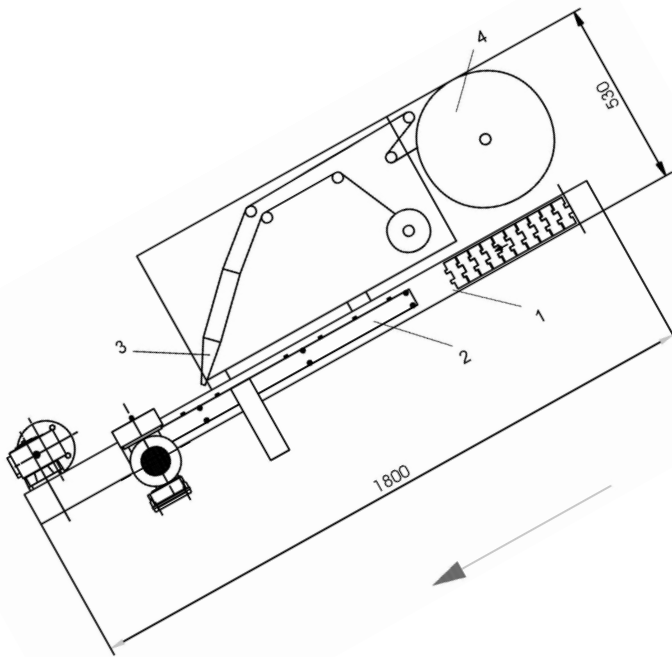

Legend:

- 1 conveyor
- 2 handle guide / hold down
- 3 dispensing blade
- 4 label roll

Technical data

Containers	tapered round, oval, square and rectangular
Diameter	5 1/8" - 13" (130 - 330 mm)
Label height	6 1/4" (160 mm)
Speed	to 70 ft/min (to 22 m/min)
Electrical specification to UL/CSA	230 V, 60 Hz, 3 PH, control 24 V
Protection	IP-54

*Do you need a machine for special requirements? We can offer a solution for this as well.
Please do not hesitate to contact us - we look forward to hearing from you !*

Langguth GmbH

Im Südfeld 17, D-48308 Senden-Bösensell
Tel.: +49 (0) 2536-806-0, Fax: + 49 (0) 2536-806-66
E-Mail: info@langguth.com
Internet: <http://www.langguth.com>

Priority One Packaging Machinery Ltd.

815 Bridge Street
Waterloo ON N2V 2M7
Phone: 519-746-6950, Fax: 519-746-3578
Internet: <http://www.priorityonepackaging.com>